



US009847058B2

(12) **United States Patent**
Lai et al.

(10) **Patent No.:** **US 9,847,058 B2**
(45) **Date of Patent:** **Dec. 19, 2017**

(54) **PIXEL UNIT STRUCTURE OF ORGANIC LIGHT EMITTING DIODE DISPLAY PANEL AND DRIVING MECHANISM THEREOF**

(58) **Field of Classification Search**
CPC G09G 3/3233
USPC 345/82
See application file for complete search history.

(71) Applicant: **HON HAI PRECISION INDUSTRY CO., LTD.**, New Taipei (TW)

(56) **References Cited**

(72) Inventors: **Chung-Wen Lai**, New Taipei (TW);
Sheng-Han Li, New Taipei (TW)

U.S. PATENT DOCUMENTS

(73) Assignee: **HON HAI PRECISION INDUSTRY CO., LTD.**, New Taipei (TW)

| | | | | | |
|--------------|-----|---------|-----|-------|-------------|
| 2007/0040772 | A1* | 2/2007 | Kim | | G09G 3/3233 |
| | | | | | 345/76 |
| 2011/0193856 | A1* | 8/2011 | Han | | G09G 3/3233 |
| | | | | | 345/214 |
| 2012/0306840 | A1* | 12/2012 | Han | | G09G 3/003 |
| | | | | | 345/212 |
| 2013/0127815 | A1* | 5/2013 | Yoo | | G09G 3/3233 |
| | | | | | 345/212 |
| 2014/0118229 | A1* | 5/2014 | Han | | G09G 3/3233 |
| | | | | | 345/82 |

(*) Notice: Subject to any disclaimer, the term of this patent is extended or adjusted under 35 U.S.C. 154(b) by 69 days.

(21) Appl. No.: **14/812,546**

* cited by examiner

(22) Filed: **Jul. 29, 2015**

Primary Examiner — Long D Pham
(74) *Attorney, Agent, or Firm* — ScienBiziP, P.C.

(65) **Prior Publication Data**
US 2016/0148574 A1 May 26, 2016

(30) **Foreign Application Priority Data**
Nov. 26, 2014 (TW) 103141080 A

(57) **ABSTRACT**
A pixel unit structure of an organic light emitting diode display panel includes a switch transistor, a storage capacitor, an organic light emitting diode, a driving transistor, a first control circuit, and a second control circuit. The organic light emitting diode is controlled by the driving transistor and the first control circuit to emit light. The pixel unit operates in a number of time events repeating in sequence.

(51) **Int. Cl.**
G09G 3/32 (2016.01)
G09G 3/3233 (2016.01)
(52) **U.S. Cl.**
CPC ... **G09G 3/3233** (2013.01); **G09G 2300/0861** (2013.01)

5 Claims, 5 Drawing Sheets

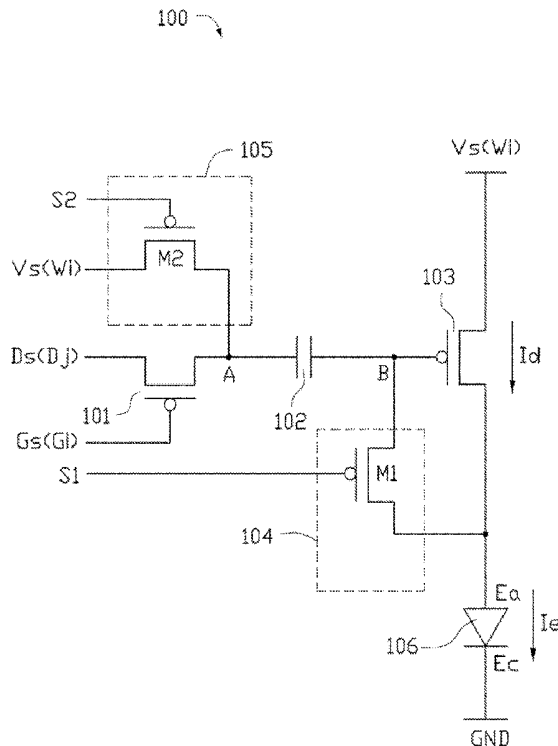

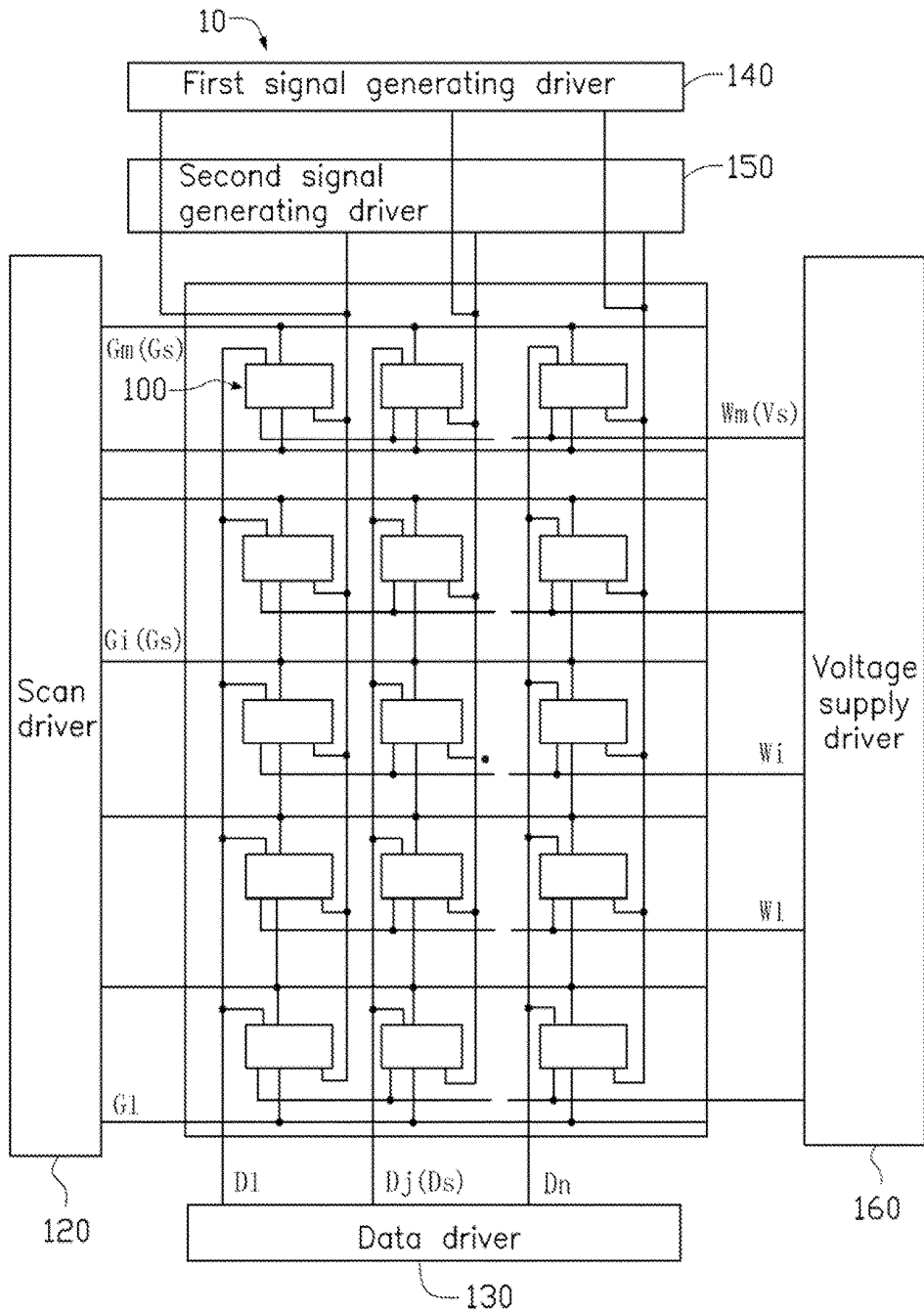

FIG. 1

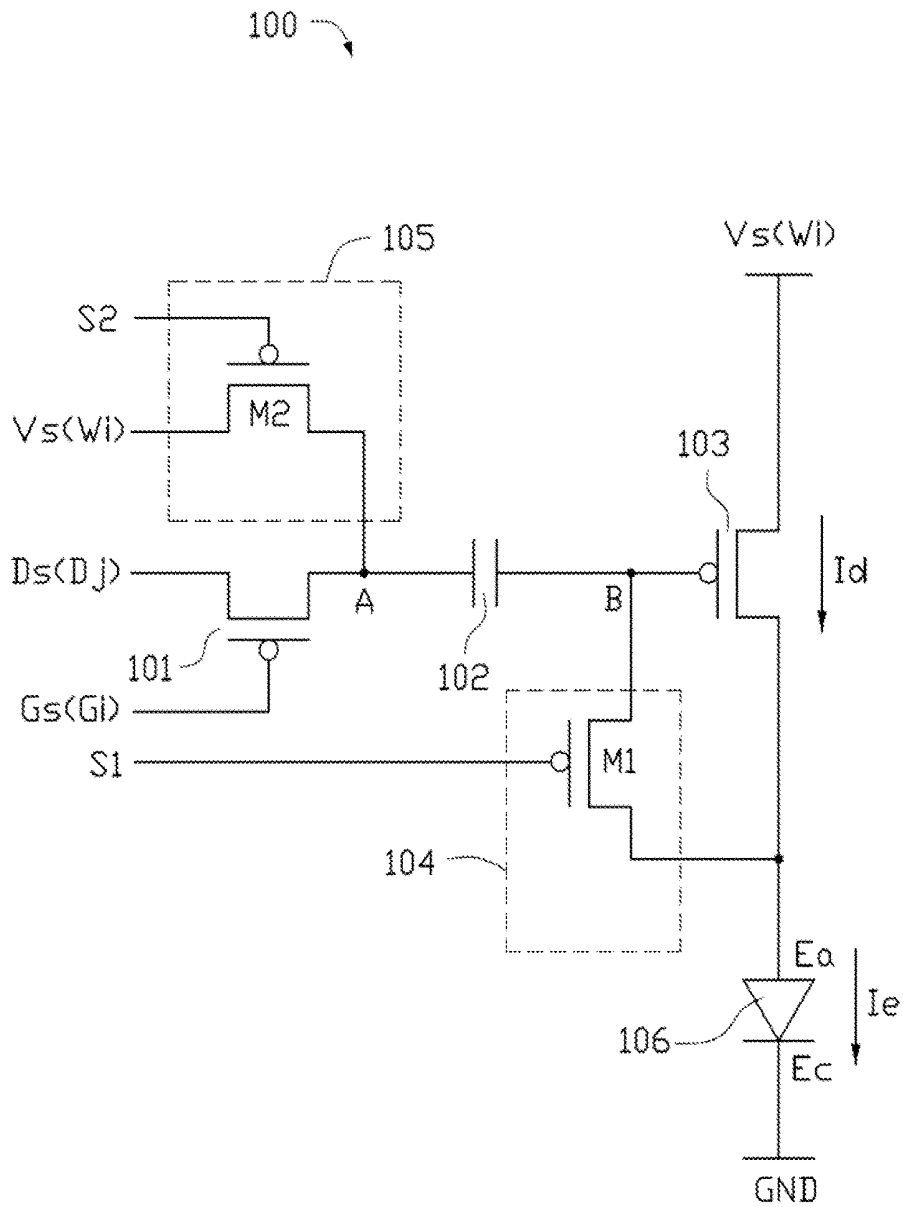

FIG. 2

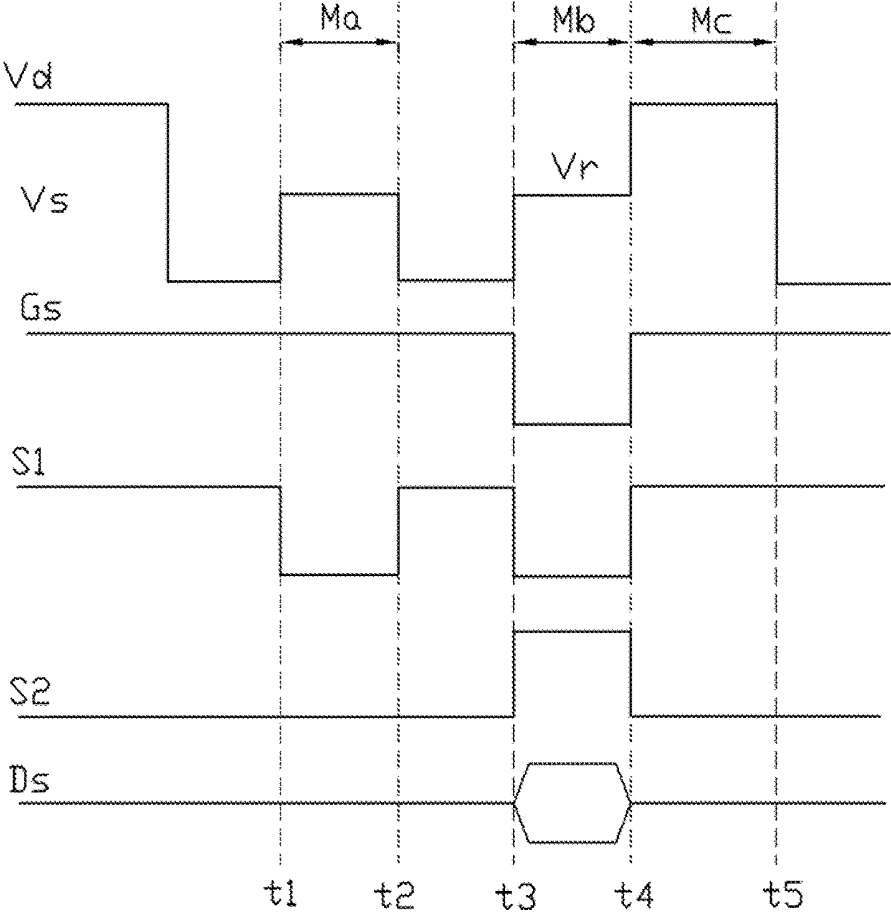

FIG. 3

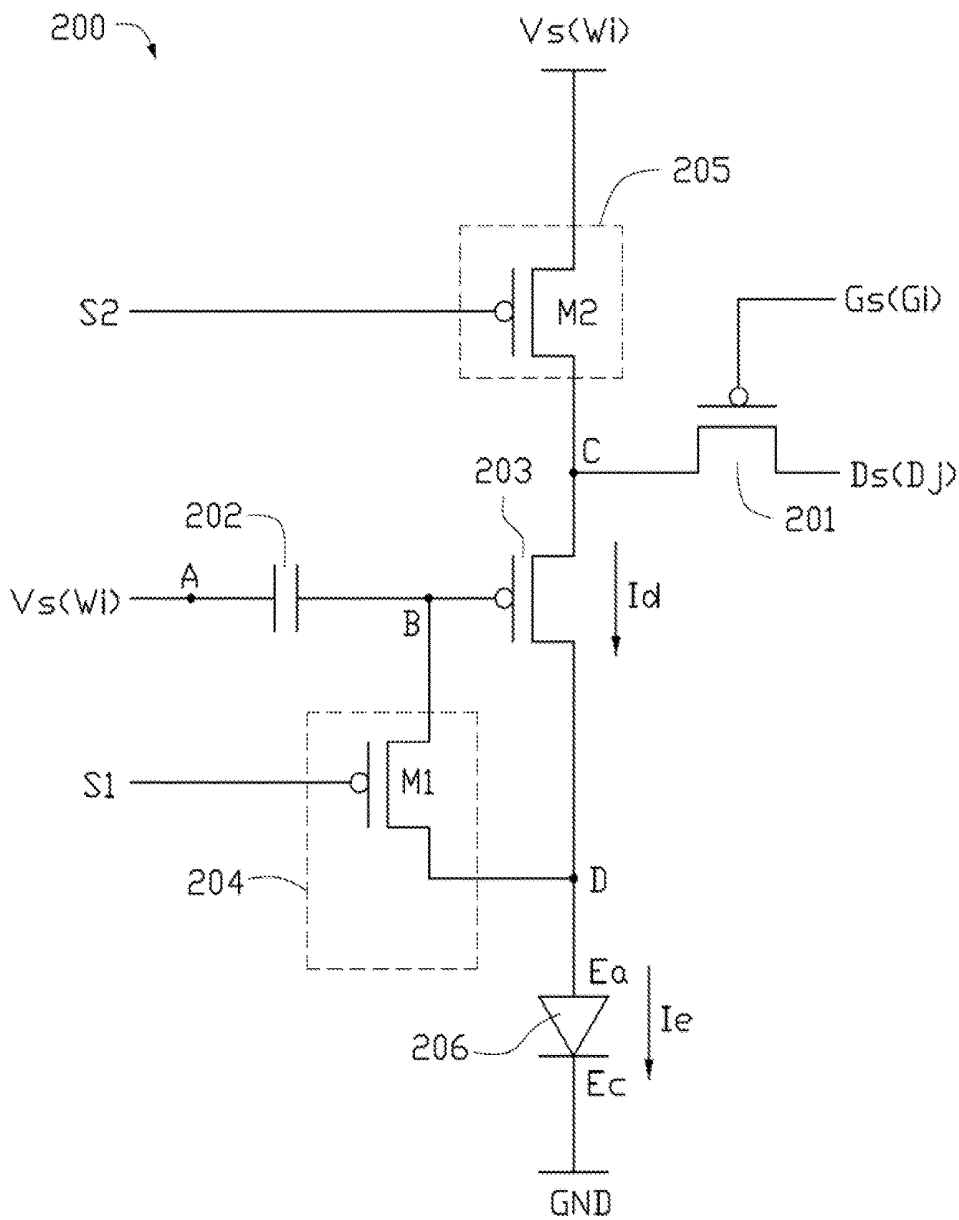

FIG. 4

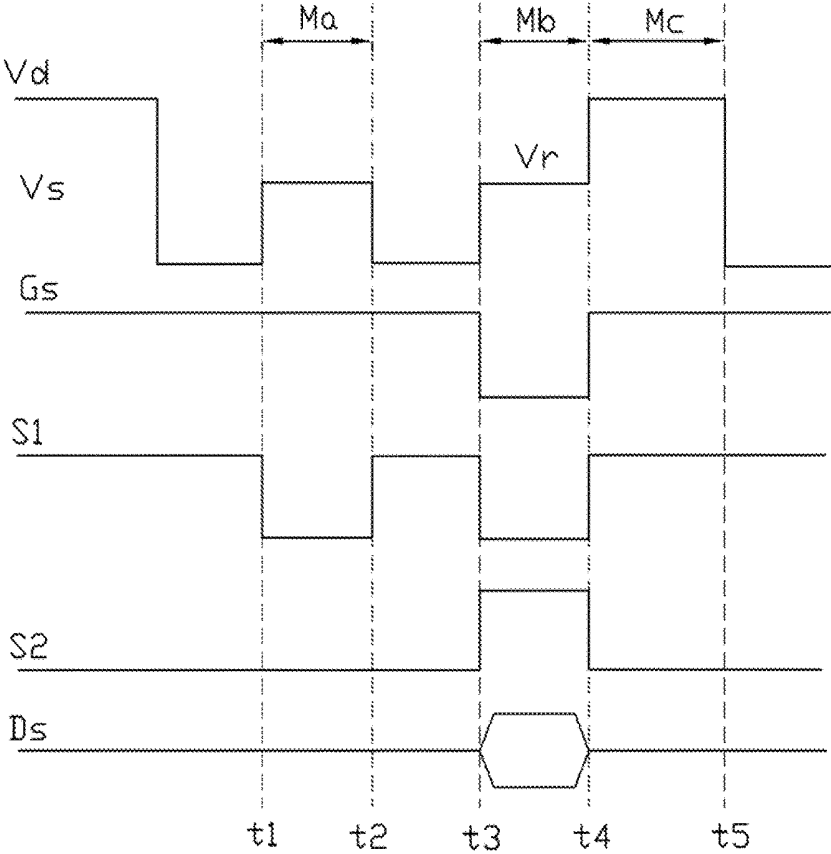

FIG. 5

PIXEL UNIT STRUCTURE OF ORGANIC LIGHT EMITTING DIODE DISPLAY PANEL AND DRIVING MECHANISM THEREOF

FIELD

The subject matter herein generally relates to organic light emitting diode (OLED) display panels, and more particularly to an OLED pixel unit structure and driving means of the OLED pixel unit.

BACKGROUND

Generally, organic light emitting diodes (OLED) used in OLED display panels are classified as active matrix OLEDs (AMOLEDs) or passive matrix OLEDs (PMOLEDs). AMOLED display panels may include a driving transistor and a storage capacitor. The storage capacitor stores a data signal. The driving transistor provides a driving current to the OLED to emit light according to the data signal stored in the storage capacitor.

BRIEF DESCRIPTION OF THE DRAWINGS

Implementations of the present technology will now be described, by way of example only, with reference to the attached figures.

FIG. 1 is a circuit diagram of an embodiment of an organic light emitting diode display panel.

FIG. 2 is a circuit diagram of a first embodiment of a pixel unit structure of FIG. 1.

FIG. 3 is a driving sequence diagram of the pixel unit structure of FIG. 2.

FIG. 4 is a circuit diagram of a second embodiment of a pixel unit structure of FIG. 1.

FIG. 5 is a driving sequence diagram of the pixel unit structure of FIG. 4.

DETAILED DESCRIPTION

It will be appreciated that for simplicity and clarity of illustration, where appropriate, reference numerals have been repeated among the different figures to indicate corresponding or analogous elements. In addition, numerous specific details are set forth in order to provide a thorough understanding of the embodiments described herein. However, it will be understood by those of ordinary skill in the art that the embodiments described herein can be practiced without these specific details. In other instances, methods, procedures and components have not been described in detail so as not to obscure the related relevant feature being described. The drawings are not necessarily to scale and the proportions of certain parts may be exaggerated to better illustrate details and features. The description is not to be considered as limiting the scope of the embodiments described herein.

Several definitions that apply throughout this disclosure will now be presented.

The term "coupled" is defined as connected, whether directly or indirectly through intervening components, and is not necessarily limited to physical connections. The connection can be such that the objects are permanently connected or releasably connected. The term "comprising" means "including, but not necessarily limited to"; it specifically indicates open-ended inclusion or membership in a so-described combination, group, series and the like.

FIG. 1 illustrates an embodiment of a structure of an electronic display panel 10. In at least one embodiment, the electronic display panel 10 is an organic light emitting diode (OLED) display panel. The electronic display panel 10 can include a scan driver 120, a data driver 130, a first signal generating driver 140, a second signal generating driver 150, a voltage supply driver 160, and a plurality of pixel units 100. Each pixel unit 100 can be electrically coupled to the scan driver 120, the data driver 130, the first signal generating driver 140, the second signal generating driver 150, and the voltage supply driver 160 to receive corresponding signals. Each pixel unit 100 can operate in a plurality of time events repeating in sequence to improve a display quality of the electronic display panel 10.

A plurality of scan lines G1-Gm can extend from the scan driver 120. The scan driver 120 can generate scan signals Gs, and each scan line G1-Gm can transmit the scan signals Gs to corresponding pixel units 100 arranged along the scan line. A plurality of data lines D1-Dn can extend from the data driver 130. The data driver 130 can generate data signals Ds, and each data line D1-Dn can transmit the data signals Ds to corresponding pixel units 100 arranged along the data line. A plurality of first control signal lines (not labeled) can extend from the first signal generating driver 140. The first signal generating driver 140 can generate first control signals S1 (shown in FIG. 2), and each first control signal line can transmit the first control signals S1 to corresponding pixel units 100 arranged along the first control signal line. A plurality of second control signal lines (not labeled) can extend from the second signal generating driver 150. The second signal generating driver 150 can generate second control signals S2 (shown in FIG. 2), and each second control signal line can transmit the second control signals S2 to corresponding pixel units 100 arranged along the second control signal line. A plurality of voltage lines W1-Wm can extend from the voltage supply driver 160. The voltage supply driver 160 can generate voltage signals Vs, and each voltage line can transmit the voltage signals Vs to corresponding pixel units 100 arranged along the voltage line.

FIG. 2 illustrates a first embodiment of a structure of each pixel unit 100. Each pixel unit 100 can include a switch transistor 101, a storage capacitor 102, a driving transistor 103, a first control circuit 104, a second control circuit 105, and an organic light emitting diode (OLED) 106. The switch transistor 101 can be electrically coupled to the corresponding scan line Gi and the corresponding data line Dj to receive the scan signal Gs and the data signal Ds, respectively. The storage capacitor 102 can receive the data signal Ds from the switch transistor 101. The driving transistor 103 is electrically coupled to the corresponding voltage supply line Wi to receive the voltage signal Vs and can output a driving current Id to drive the OLED 106 to emit light corresponding to the data signal Ds. The first control circuit 104 is electrically coupled to the corresponding first control signal line to receive the first control signal S1 to cause the driving transistor 103 to be in a conducting state. The second control circuit 105 is electrically coupled to the corresponding voltage line Wi to receive the voltage signal Vs, and electrically coupled to the corresponding second control signal line to receive the second control signal S2 to relay the voltage signal Vs to the storage capacitor 102.

The OLED 106 can include an anode terminal Ea and a cathode terminal Ec. The anode terminal Ea can be electrically coupled to the driving transistor 103 and the first control circuit 104, and the cathode terminal Ec can be electrically coupled to ground Gnd.

A gate electrode of the switch transistor **101** can be electrically coupled to the scan line G_i to receive the scan signal G_s . A source electrode of the switch transistor **101** can be electrically coupled to the data line D_j to receive the data signal D_s . A drain electrode of the switch transistor **101** can be electrically coupled to the storage capacitor **102** to relay the data signal D_s to the storage capacitor **102**.

The storage capacitor **102** can include a first connecting terminal A and a second connecting terminal B. The first connecting terminal A can be electrically coupled to the drain electrode of the switch transistor **101** and electrically coupled to the second control circuit **105**. The second connecting terminal B can be electrically coupled to the driving transistor **103** and the first control circuit **104**.

A gate electrode of the driving transistor **103** can be electrically coupled to the second connecting terminal B of the storage capacitor **102**. A source electrode of the driving transistor **103** can be electrically coupled to the voltage line W_i to receive the voltage signal V_s . A drain electrode of the driving transistor **103** can be electrically coupled to the first control circuit **104** and the OLED **106**.

The first control circuit **104** can include a first control transistor **M1**. A gate electrode of the first control transistor **M1** can be electrically coupled to the first control signal line to receive the first control signal S_1 . A source electrode of the first control transistor **M1** can be electrically coupled to the second connecting terminal B of the storage capacitor **102**. A drain electrode of the first control transistor **M1** can be electrically coupled to the drain electrode of the driving transistor **103**. When the first control transistor **M1** receives the first control signal S_1 to be in a conducting state, the gate electrode and the drain electrode of the driving transistor **103** are electrically coupled together to become a diode-connected transistor. When the first control transistor **M1** is in a non-conducting state, the gate electrode and the drain electrode of the driving transistor **103** are electrically uncoupled from each other.

The second control circuit **105** can include a second control transistor **M2**. A gate electrode of the second control transistor **M2** can be electrically coupled to the second control signal line to receive the second control signal S_2 . A source electrode of the second control transistor **M2** can be electrically coupled to the voltage line W_i to receive the voltage signal V_s . A drain electrode of the second control transistor **M2** can be electrically coupled to the first connecting terminal A of the storage capacitor **102**. When the second control signal S_2 causes the second control transistor **M2** to be in a conducting state, the second control transistor **M2** can relay the voltage signal V_s to the first connecting terminal A to make a voltage of the first connecting terminal A equal to the voltage of the voltage signal V_s .

In at least one embodiment, the switch transistor **101**, the driving transistor **103**, the first control transistor **M1**, and the second control transistor **M2** are P-channel metal oxide semiconductors. The switch transistor **101** is in a conducting state upon receiving the scan signal G_s at a low voltage level, and in a non-conducting state upon receiving the scan signal G_s at a high-voltage level. The first control transistor **M1** is in a conducting state upon receiving the first control signal S_1 at a low voltage level, and in a non-conducting state upon receiving the first control signal S_1 at a high-voltage level. The second control transistor **M2** is in a conducting state upon receiving the second control signal S_2 at a low voltage level, and in a non-conducting state upon receiving the second control signal S_2 at a high voltage level.

Referring to FIG. 3, the plurality of time events of each pixel unit **100** can include five time events.

At a first time event t_1 , the first control transistor **M1** receives the first control signal S_1 at the low voltage level to be in the conducting state, the second control transistor **M2** receives the second control signal S_2 at the low voltage level to be in the conducting state, and the voltage signal V_s is received by the second control transistor **M2** as the reference voltage V_r . A time period between the first time event t_1 and a second time event t_2 is a discharge event M_a . During the discharge event M_a , the second connecting terminal B is electrically coupled to the drain electrode of the first control transistor **M1**. The reference voltage V_r is relayed from the second control transistor **M2** to the first connecting terminal A to make the voltage of the first connecting terminal A equal to the reference voltage V_r . Thus, a conductive path is cooperatively formed by the first connecting terminal A, the second connecting terminal B, and the first control transistor **M1**. Electric charge in the storage capacitor **102** can be discharged through the conductive path. The discharge of the electric charge through the conductive path can ensure more accurate storage of the data signal D_s in the storage capacitor **102**.

At the second time event t_2 , the first control transistor **M1** receives the first control signal S_1 at the high voltage level to be in the non-conducting state. The voltage signal V_s is changed from the reference voltage V_r to the low voltage level.

At a third time event t_3 , the switch transistor **101** receives the scan signal G_s at the low voltage level to be in the conducting state, the first control transistor **M1** receives the first control signal S_1 at the low voltage level to be in the conducting state, and the voltage signal V_s is changed from the low voltage level to the reference voltage V_r . A time period between the third time event t_3 and a fourth time event t_4 is a data loading event M_b . During the data loading event M_b , the data signal D_s is relayed from the switch transistor **101** to the first connecting terminal A to make the voltage of the first connecting terminal A equal to a voltage of the data signal D_s (i.e., V_{ds}). A voltage of the second connecting terminal B is equal to the difference between the reference voltage V_r and a threshold voltage V_{th} of the driving transistor **103** (i.e., $V_r - V_{th}$). Thus, a voltage difference between the first connecting terminal A and the second connecting terminal B of the storage capacitor **102** is equal to $(V_{ds} - (V_r - V_{th}))$. The threshold voltage V_{th} is equal to the minimum voltage required for the driving transistor **103** to transition from the non-conducting state to the conducting state.

At the fourth time event t_4 , the switch transistor **101** receives the scan signal G_s at the high voltage level to be in the non-conducting state, the first control transistor **M1** receives the first control signal S_1 at the high voltage level to be in the non-conducting state, the second control transistor **M2** receives the second control signal S_2 at the low voltage level to be in the conducting state, and the voltage signal V_s is changed from the reference voltage V_r to the driving voltage V_d . A time period between the fourth time event t_4 and a fifth time event t_5 is a display event M_c . During the display event M_c , the second control transistor **M2** in the conducting state relays the driving voltage V_d to the first connecting terminal A to make the voltage of the first connecting terminal A equal to the driving voltage V_d , thereby making the voltage of the second connecting terminal B equal to $(V_d - (V_{ds} - (V_r - V_{th})))$, or $(V_d - V_{ds} + V_r - V_{th})$. The driving transistor **103** is controlled by the voltage of the second connecting terminal B to be in the conducting state,

and the driving voltage V_d received by the source electrode of the driving transistor **103** causes the driving transistor **103** to output a driving current I_d to the OLED **106**. The OLED **106** can emit light corresponding to the data signal D_s upon receiving the driving current I_d . A current I_e flowing through the OLED **106** is directly proportional to $(V_{sg}-V_{th})^2$, wherein V_{sg} represents the voltage difference between the source electrode and the gate electrode of the driving transistor **103**. Because the voltage of the source electrode is equal to the driving voltage V_d and the gate electrode receives the voltage of the second connecting terminal B, V_{sg} is equal to $(V_d-(V_d-V_{ds}+V_r-V_{th}))$, or $(-V_r+V_{ds}+V_{th})$. Thus, the current flowing through the OLED **106** is directly proportional to $(V_{ds}-V_r)^2$.

At the fifth time event t_5 , the voltage signal V_s is changed from the driving voltage V_d to the low voltage level.

FIG. 4 illustrates a second embodiment of a structure of a pixel unit **200**. In the second embodiment, each pixel unit **200** can include a switch transistor **201**, a storage capacitor **202**, a driving transistor **203**, a first control circuit **204**, a second control circuit **205**, and an OLED **206**. The switch transistor **201** can be electrically coupled to the corresponding scan line G_i to receive the scan signal G_s , and electrically coupled to the corresponding data line D_j to receive the data signal D_s . The driving transistor **203** can receive the data signal D_s from the switch transistor **201** and transmit a driving current I_d to the OLED **206**. The storage capacitor **202** can be electrically coupled to the corresponding voltage line W_i to receive the voltage signal V_s . The first control circuit **204** can be electrically coupled to the corresponding first control signal line to receive the first control signal S_1 to cause the driving transistor **203** to be in a conducting state. The second control circuit **205** can be electrically coupled to the corresponding voltage line W_i to receive the voltage signal V_s , and electrically coupled to the corresponding second control signal line to receive the second control signal S_2 to relay the voltage signal V_s to the driving transistor **203**.

The OLED **206** can include an anode terminal E_a and a cathode terminal E_c . The anode terminal E_a can be electrically coupled to the driving transistor **203** and the first control circuit **204**. The cathode terminal E_c can be electrically coupled to ground GND.

A gate electrode of the switch transistor **201** can be electrically coupled to the scan line G_i to receive the scan signal G_s . A source electrode of the switch transistor **201** can be electrically coupled to the data line D_j to receive the data signal D_s . A drain electrode of the switch transistor **201** can be electrically coupled to the driving transistor **203** to relay the data signal D_s to the driving transistor **203**.

The storage capacitor **202** can include a first connecting terminal A and a second connecting terminal B. The first connecting terminal A can be electrically coupled to the voltage line W_i to receive the voltage signal V_s . The second connecting terminal B can be electrically coupled to the driving transistor **203** and the first control circuit **204**.

The driving transistor **203** can include a third connecting terminal C and a fourth connecting terminal D. A gate electrode of the driving transistor **203** can be electrically coupled to the second connecting terminal B of the storage capacitor **202**. A source electrode of the driving transistor **203** electrically coupled to the third connecting terminal C can be electrically coupled to the drain electrode of the switch transistor **201** to receive the data signal D_s . A drain electrode of the driving transistor **203** electrically coupled to the fourth connecting terminal D can be electrically coupled to the OLED **206**.

The first control circuit **204** can include a first control transistor **M1**. A gate electrode of the first control transistor **M1** can be electrically coupled to the first control signal line to receive the first control signal S_1 . A source electrode of the first control transistor **M1** can be electrically coupled to the second connecting terminal B of the storage capacitor **202**. A drain electrode of the first control transistor **M1** can be electrically coupled to the fourth connecting terminal D. When the first control transistor **M1** receives the first control signal S_1 to be in a conducting state, the gate electrode and the drain electrode of the driving transistor **203** are electrically coupled together to become a diode-connected transistor. When the first control transistor **M1** is in a non-conducting state, the gate electrode and the drain electrode of the driving transistor **203** are electrically uncoupled from each other.

The second control circuit **205** can include a second control transistor **M2**. A gate electrode of the second control transistor **M2** can be electrically coupled to the second control signal line to receive the second control signal S_2 . A source electrode of the second control transistor **M2** can be electrically coupled to the voltage line W_i to receive the voltage signal V_s . A drain electrode of the second control transistor **M2** can be electrically coupled to the third connecting terminal C. When the second control signal S_2 causes the second control transistor **M2** to be in the conducting state, the second control transistor **M2** relays the voltage signal V_s to the third connecting terminal C to make a voltage of the third connecting terminal C equal to the voltage of the voltage signal V_s .

In at least one embodiment, the switch transistor **201**, the driving transistor **203**, the first control transistor **M1**, and the second control transistor **M2** are P-channel metal oxide semiconductors. The switch transistor **201** is in a conducting state upon receiving the scan signal G_s at a low voltage level, and in a non-conducting state upon receiving the scan signal G_s at a high-voltage level. The first control transistor **M1** is in a conducting state upon receiving the first control signal S_1 at a low voltage level, and in a non-conducting state upon receiving the first control signal S_1 at a high-voltage level. The second control transistor **M2** is in a conducting state upon receiving the second control signal S_2 at a low voltage level, and in a non-conducting state upon receiving the second control signal S_2 at a high voltage level.

Referring to FIG. 5, the plurality of time events of each pixel unit **200** can include five time events.

At a first time event t_1 , the first control transistor **M1** receives the first control signal S_1 at the low voltage level to be in the conducting state, the second control transistor **M2** receives the second control signal S_2 at the low voltage level to be in the conducting state, and the voltage signal V_s is received by the second control transistor **M2** as the reference voltage V_r . A time period between the first time event t_1 and a second time event t_2 is a discharge event M_a . During the discharge event M_a , the second connecting terminal B is electrically coupled to the drain electrode of the first control transistor **M1**. The reference voltage V_r is relayed from the second control transistor **M2** to the first connecting terminal A to make the voltage of the first connecting terminal A equal to the reference voltage V_r . Thus, a conductive path is cooperatively formed by the first connecting terminal A, the second connecting terminal B, and the first control transistor **M1**. Electric charge in the storage capacitor **202** can be discharged through the conductive path. The discharge of

the electric charge through the conductive path can ensure more accurate storage of the data signal D_s in the storage capacitor **202**.

At the second time event t_2 , the first control transistor **M1** receives the first control signal S_1 at the high voltage level to be in the non-conducting state, and the voltage signal V_s is changed from the reference voltage V_r to the low voltage level.

At a third time event t_3 , the switch transistor **201** receives the scan signal G_s at the low voltage level to be in the conducting state, the first control transistor **M1** receives the first control signal S_1 at the low voltage level to be in the conducting state, and the voltage signal V_s is changed from the low voltage level to the reference voltage V_r . A time period between the third time event t_3 and a fourth time event t_4 is a data loading event M_b . During the data loading event M_b , the data signal D_s is relayed from the switch transistor **201** to the third connecting terminal C to make the voltage of the third connecting terminal C equal to a voltage of the data signal D_s (i.e., V_{ds}). A voltage of the second connecting terminal B is equal to the difference between the voltage of the data signal D_s and a threshold voltage V_{th} of the driving transistor **203** (i.e., $V_{ds}-V_{th}$). Thus, a voltage difference between the first connecting terminal A and the second connecting terminal B of the storage capacitor **202** is equal to $(V_r-(V_{ds}-V_{th}))$. The threshold voltage V_{th} is equal to the minimum voltage required for the driving transistor **203** to transition from the non-conducting state to the conducting state.

At the fourth time event t_4 , the switch transistor **201** receives the scan signal G_s at the high voltage level to be in the non-conducting state, the first control transistor **M1** receives the first control signal S_1 at the high voltage level to be in the non-conducting state, the second control transistor **M2** receives the second control signal S_2 at the low voltage level to be in the conducting state, and the voltage signal V_s is changed from the reference voltage V_r to the driving voltage V_d . A time period between the fourth time event t_4 and a fifth time event t_5 is a display event M_c . During the display event M_c , the second control transistor **M2** in the conducting state relays the driving voltage V_d to the third connecting terminal C to make the voltage of the third connecting terminal C equal to the driving voltage V_d . The voltage of the first connecting terminal A is equal to the reference voltage V_r . Thus, the voltage of the second connecting terminal B equal to $(V_d-(V_r-(V_{ds}-V_{th})))$, or $(V_d-V_r+V_{ds}-V_{th})$. The driving transistor **203** is controlled by the voltage of the second connecting terminal B to be in the conducting state, and the driving voltage V_d received by the source electrode of the driving transistor **203** causes the driving transistor **203** to output a driving current I_d to the OLED **206**. The OLED **206** can emit light corresponding to the data signal D_s upon receiving the driving current I_d . A current I_e flowing through the OLED **206** is directly proportional to $(V_{sg}-V_{th})^2$, wherein V_{sg} represents the voltage difference between the source electrode and the gate electrode of the driving transistor **203** (i.e., the voltage difference between the third connecting terminal C and the second connecting terminal B). Because the source electrode receives the driving voltage V_d and the gate electrode receives the voltage of the second connecting terminal B , V_{sg} is equal to $(V_d-(V_d-V_r+V_{ds}-V_{th}))$, or $(V_r-V_{ds}+V_{th})$. Thus, the current flowing through the OLED **206** is directly proportional to $(V_r-V_{ds})^2$.

At the fifth time event t_5 , the voltage signal V_s is changed from the driving voltage V_d to the low voltage level.

For the first and second embodiments of the pixel units **100** and **200**, the time events t_1 - t_5 repeat in sequence for each pixel unit **100** and **200**, thereby ensuring accurate storage of the data signals D_s . The current I_e flowing through the OLED **106**, **206** is related to the voltage of the data signal D_s and the reference voltage V_r , so the current I_e flowing through the OLED **106**, **206** is not fluctuated by the threshold voltage V_{th} or the driving voltage V_d of the driving transistor **103**, **203**. Furthermore, the reference voltage V_r supplied by the voltage supply driver **160** to different pixel units **100**, **200** is the same, so even when the driving voltage V_d supplied to the pixel units **100**, **200** fluctuates, an image display quality of the electronic display panel **10** is improved.

The embodiments shown and described above are only examples. Even though numerous characteristics and advantages of the present technology have been set forth in the foregoing description, together with details of the structure and function of the present disclosure, the disclosure is illustrative only, and changes may be made in the detail, including in matters of shape, size and arrangement of the parts within the principles of the present disclosure up to, and including, the full extent established by the broad general meaning of the terms used in the claims.

What is claimed is:

1. A pixel unit structure of an organic light emitting diode display panel, the pixel unit structure comprising:

- a switch transistor configured to receive a scan signal from a scan driver, and electrically a data signal from a data driver;
 - a storage capacitor configured to receive the data signal from the switch transistor;
 - an organic light emitting diode configured to emit light corresponding to the data signal;
 - a driving transistor configured to receive a voltage signal from a voltage supply driver and transmit a driving current to the organic light emitting diode;
 - a first control circuit configured to receive a first control signal from a first signal generating driver; and
 - a second control circuit configured to receive the voltage signal from the voltage supply driver and a second control signal from a second signal generating driver, wherein the organic light emitting diode is controlled by the driving transistor and the first control circuit to emit light,
- wherein a voltage level of the voltage signal is one of a low voltage level, a reference voltage higher than the low voltage level, and a driving voltage higher than the reference voltage,
- wherein the scan signal, the voltage signal, the first control signal, and the second control signal control the pixel unit to operate in a plurality of time events repeating in sequence;
- wherein the organic light emitting diode comprises an anode terminal electrically coupled to the driving transistor and the first control circuit, and comprises a cathode terminal electrically coupled to ground;
- a gate electrode of the switch transistor is electrically coupled to a scan line to receive the scan signal from the scan driver;
 - a source electrode of the switch transistor is electrically coupled to a data line to receive the data signal from the data driver;
 - a drain electrode of the switch transistor is electrically coupled to the storage capacitor to relay the data signal to the storage capacitor;

the storage capacitor comprises a first connecting terminal electrically coupled to the drain electrode of the switch transistor and electrically coupled to the second control circuit, and comprises a second connecting terminal electrically coupled to the driving transistor and the first control circuit;

a gate electrode of the driving transistor is electrically coupled to the second connecting terminal of the storage capacitor;

a source electrode of the driving transistor is electrically coupled to a voltage line to receive the voltage signal from the voltage supply driver;

a drain electrode of the driving transistor is electrically coupled to the first control circuit and the organic light emitting diode;

the first control circuit comprises a first control transistor;

a gate electrode of the first control transistor is electrically coupled to a first control signal line to receive the first control signal from the first signal generating driver;

a source electrode of the first control transistor is electrically coupled to the second connecting terminal of the storage capacitor;

a drain electrode of the first control transistor is electrically coupled to the drain electrode of the driving transistor;

the gate electrode and the drain electrode of the driving transistor are electrically coupled together to become a diode-connected transistor when the first control transistor is in a conducting state;

the gate electrode and the drain electrode of the driving transistor are electrically uncoupled from each other when the first control transistor is in a non-conducting state;

the second control circuit comprises a second control transistor;

a gate electrode of the second control transistor is electrically coupled to a second control signal line to receive the second control signal from the second signal generating driver;

a source electrode of the second control transistor is electrically coupled to the voltage line to receive the voltage signal from the voltage supply driver;

a drain electrode of the second control transistor is electrically coupled to the first connecting terminal of the storage capacitor; and

when the second control transistor is in a conducting state, the second control transistor relays the voltage signal to the first connecting terminal to make a voltage of the first connecting terminal equal to the voltage of the voltage signal;

wherein the switch transistor, the driving transistor, the first control transistor, and the second control transistor are P-channel metal oxide semiconductors;

the switch transistor is in a conducting state upon receiving the scan signal at a low voltage level, and in a non-conducting state upon receiving the scan signal at a high-voltage level;

the first control transistor is in a conducting state upon receiving the first control signal at a low voltage level, and in a non-conducting state upon receiving the first control signal at a high-voltage level;

the second control transistor is in a conducting state upon receiving the second control signal at a low voltage level, and in a non-conducting state upon receiving the second control signal at a high voltage level; and

the scan signal, the first control signal, and the second control signal control the pixel unit to operate in five time events repeating in sequence; and

wherein at a first time event:

the first control transistor is in the conducting state;

the second connecting terminal is electrically coupled to the drain electrode of the first control transistor;

the second control transistor is in the conducting state;

the second control transistor in the conducting state relays the voltage signal as the reference voltage to the first connecting terminal to make the voltage of the first connecting terminal equal to the reference voltage; and

electric charge in the storage capacitor is discharged through a conduction path formed by the first connecting terminal, the second connecting terminal, and the first control transistor.

2. The pixel unit structure as in claim 1, wherein at a second time event:

the first control transistor is in the non-conducting state; and

the voltage signal is changed to the low voltage level.

3. The pixel unit structure as in claim 2, wherein at a third time event:

the switch transistor is in the conducting state;

the switch transistor in the conducting state receives the data signal;

the switch transistor relays the data signal to the first connecting terminal to make the voltage of the first connecting terminal equal to the voltage of the data signal;

the first control transistor is in the conducting state;

the voltage signal is changed from the low voltage level to the reference voltage; and

a voltage of the second connecting terminal is equal to the difference between the reference voltage and a threshold voltage of the driving transistor.

4. The pixel unit structure as in claim 3, wherein at a fourth time event:

the switch transistor is in the non-conducting state;

the second control transistor is in the conducting state;

the voltage signal is changed from the reference voltage to the driving voltage;

the second control transistor relays the driving voltage to the first connecting terminal to make the voltage of the first connecting terminal equal to the driving voltage;

the voltage of the second connecting terminal is equal to the sum of the difference between the driving voltage and the voltage of the data signal and the difference between the reference voltage and the threshold voltage of the driving transistor;

the driving transistor is controlled by the voltage of the second connecting terminal to be in the conducting state;

the driving transistor in the conducting state is driven by the driving voltage to output the driving current to the organic light emitting diode;

the light emitting diode, upon receiving the driving current, emits light; and

a current passing through the organic light emitting diode is directly proportional to the square of the difference between the voltage of the data signal and the reference voltage.

5. The pixel unit structure as in claim 4, wherein at a fifth time event:

the voltage signal is changed from the driving voltage to the low voltage level; and

the organic light emitting diode stops emitting light.

| | | | |
|----------------|---------------------------------|-----------------------|------------|
| 专利名称(译) | 有机发光二极管显示面板的像素单元结构及其驱动机构 | | |
| 公开(公告)号 | US9847058 | 公开(公告)日 | 2017-12-19 |
| 申请号 | US14/812546 | 申请日 | 2015-07-29 |
| [标]申请(专利权)人(译) | 鸿海精密工业股份有限公司 | | |
| 申请(专利权)人(译) | 鸿海精密工业股份有限公司. | | |
| 当前申请(专利权)人(译) | 鸿海精密工业股份有限公司. | | |
| [标]发明人 | LAI CHUNG WEN LI SHENG HAN | | |
| 发明人 | LAI, CHUNG-WEN LI, SHENG-HAN | | |
| IPC分类号 | G09G3/32 G09G3/3233 | | |
| CPC分类号 | G09G3/3233 G09G2300/0861 | | |
| 优先权 | 103141080 2014-11-26 TW | | |
| 其他公开文献 | US20160148574A1 | | |
| 外部链接 | Espacenet | USPTO | |

摘要(译)

有机发光二极管显示面板的像素单元结构包括开关晶体管，存储电容器，有机发光二极管，驱动晶体管，第一控制电路和第二控制电路。有机发光二极管由驱动晶体管和第一控制电路控制以发光。像素单元在顺序重复的多个时间事件中操作。

